

USE COURSE WOOD WORKING TOOLS FOR CUTTING AND DRILLING

ALLOW FOR THERMAL EXPANSION AND SHRINKAGE BY LEAVING GAPS BETWEEN END OF BOARDS

USE PLATED SCREWS TO JOIN BOARD TO STAKE

DO NO SCREW BOTH BOARDS TOGETHER

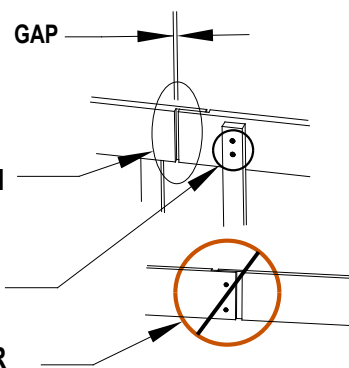

NOMINAL DESCRIPTION	PRODUCT NUMBER	COLOR	ACTUAL DIMENSION D x H x L	MIN. BEND RADIUS	GAP	MAXIMUM CROWN H / L
1 x 4 x 20	100036729	REDWOOD	.72in X 3.35in X 19ft 10in 1.82cm X 8.5cm X 6.04m	24"	1/4" - 1/2"	19" / 20'
	100036733	SAND				
	100059386	TEAK				
	100051993	BLACK				
2 x 4 x 20	100036731	REDWOOD	1.37in X 3.4in X 19ft 10in 3.47cm X 8.63cm X 6.04m	36"	1/2" - 3/4"	16" / 20'
	100059389	TEAK				
1 x 6 x 20	100036730	REDWOOD	.65in X 5.35in X 19ft 10in 1.65cm X 13.58cm X 6.04m	24"	1/2" - 3/4"	9" / 20'
	100082778	BLACK				
	100059387	TEAK				
2 x 6 x 16	100036732	REDWOOD	1.35in X 5.4in X 15ft 10in 3.42cm X 13.71cm X 4.82m	36"	3/4" - 1"	N/A

BENDA BOARD HEADER BOARD DETAIL # 110-A

MADE IN USA by EPIC PLASTICS
104 E. TURNER RD, LODI CA 95240
www.epicplastics.com

209.333.6161

BENDA BOARD IS INTENDED FOR NON-STRUCTURAL USE ONLY