

SEDIMENT CONTROL SOLUTIONS FOR ALL STORM WATER SYSTEMS & DEWATERING PROJECTS



You Can Depend On Dandy Products To Deliver!

HIGH PROFILE DESIGN
For Increased Visibility
In The Field

FLEX RODS
Pop open and
support

SCREEN PILLOW

**OIL-ABSORBING
FILTER MEDIA**

Dandy Products, Inc
1095 Harcourt Road, Mount Vernon, OH 43050
Customer Service: 800.591.2284 • Fax: 740.397.1946
For complete product specs and information: www.dandyproducts.com • Twitter: @dandyproducts

Manageable
3 foot containment
area

SEDIMENT CONTROL SOLUTIONS FOR ALL STORM WATER SYSTEMS & DEWATERING PROJECTS



The Storm Water Management Authority

In 1995, Dandy opened for business in Columbus, Ohio targeting the inlet protection needs of the construction industry. Their primary objective to engineer and produce the most complete line of stormwater solutions in the world drove the rapid expansion of their list of products.

In 2002, Dandy made great strides towards establishing themselves as an industry leader in stormwater filtration and inlet protection, when they partnered with Ten Cate Mirafi, a manufacturer of industrial fabrics & construction products. This relationship provided them with an instant National Distribution Network and the respectability gained from partnering with one of the largest and most visible suppliers in construction and development.

As Dandy grew and gained visibility and strength in the market, a natural shift in their partner needs developed, which led them to the decision to change their position and focus to best serve their customers.

With nationwide acceptance and use of their products, inconsistent pricing surfaced as an obstacle to competitive growth. The only solution to guaranteeing standardizing pricing was to develop their own distribution network and emerge independent of their partnership with Mirafi. The result benefited all, standardized pricing and in many cases reduction in costs due to the simplification of the process and Dandy direct availability to Distributors.

Dandy has done its best to continually improve the quality of their products and services as well as offer supportive tools that encourage industry regulatory compliance. They strive to efficiently manage every job with a can-do spirit, so that from the first client call to the final installation, customers know that Dandy delivers product and service excellence.

Dandy Products, Inc.

|| GRATE

1095 Harcourt Road
Mount Vernon, OH
43050

Customer Service:

800.591.2284

Fax: 740.397.1946

|| DEVICES

Twitter:

@dandyproducts

|| CATCH

For complete product
specs and information,
please visit our website
www.dandyproducts.com.

You Can Depend On Dandy Products To Deliver.

REINFORCED
CORNERS

Optional
outflow ports

DUMPING
STRAPS

SEDIMENT CONTROL SOLUTIONS FOR ALL STORM WATER SYSTEMS & DEWATERING PROJECTS



What Our Valued Customers Are Saying

Julio Perez
Compliance Officer at Colorado Structures, Inc.

"Dandy Products are the most cost effective, easiest installed Storm Water Compliance drain inlet protection on the market today. Working in the Storm Water Compliance industry for the last 6 years, Dandy Products have proved to be easy to install and maintain, have great filtration/water flow characteristics and are very durable and re-usable. Dandy Products meet our size variety and complexity demands in protecting all of our drain inlets. Dandy helps to keep Colorado Structures, Inc. a leader in Storm Water Compliance."

John Henderson, PE
Sr. Vice President at TenCate Geosynthetics

"Dandy Products are a cost-effective, readily identifiable way for contractors to control stormwater runoff and to show inspectors that they are complying with NPDES II....." "The complete product line, comprehensive distribution, and experience, all make Dandy Products the stormwater authority."

Dandy Products, Inc.
|| GRATE
1095 Harcourt Road
Mount Vernon, OH
43050

Customer Service:
800.591.2284
Fax: 740.397.1946

|| DEVICES

Twitter:
@dandyproducts

|| CATCH
For complete product
specs and information,
please visit our website
www.dandyproducts.com.

Manageable
2 foot containment
area

Optional
outflow ports

You Can Depend On Dandy Products To Deliver.

DUMPING
STRAPS

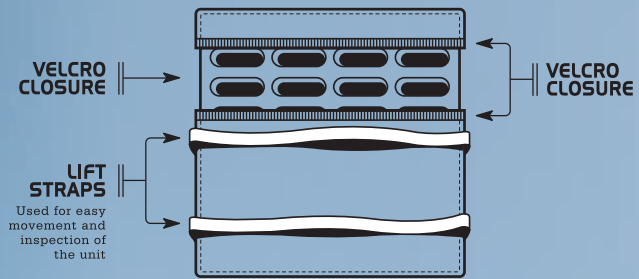

DANDY BAG®

You can tell it's Dandy the moment you open it up. Our patented flagship bag is designed to take a lot of hard knocks. Use the Dandy Bag with flat grates (including round) and mountable curbs to filter out all the sludgy sediment-laden storm water. The suspended solids are allowed to settle out of the slowed flow and are captured by the Dandy Bag prior to entering the inlet, ensuring you regulatory compliance performance.

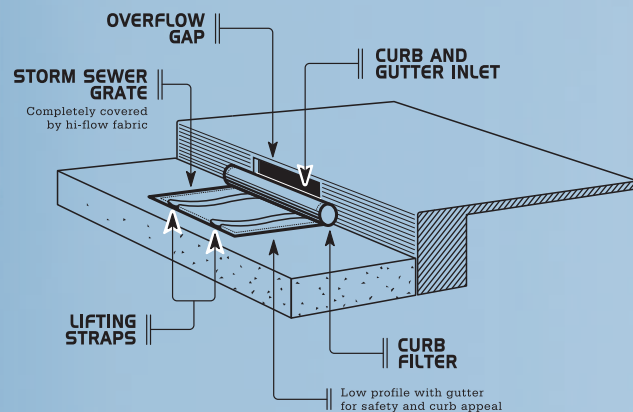
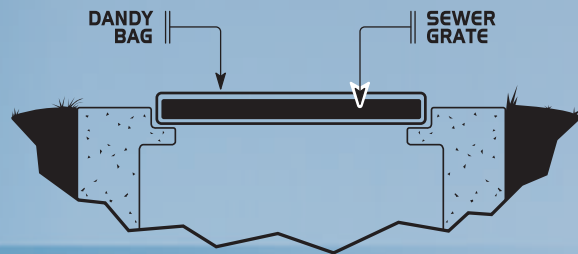

DANDY CURB BAG®

When you need to be confident of your filtration system - call on the strength of the Dandy Curb Bag. Patented and designed for use on curb and gutter inlets to filter out the most stubborn sediment-laden storm water. The suspended solids are allowed to settle out of the slowed flow and are captured by the rough and tough Dandy Curb Bag prior to entering the inlet.

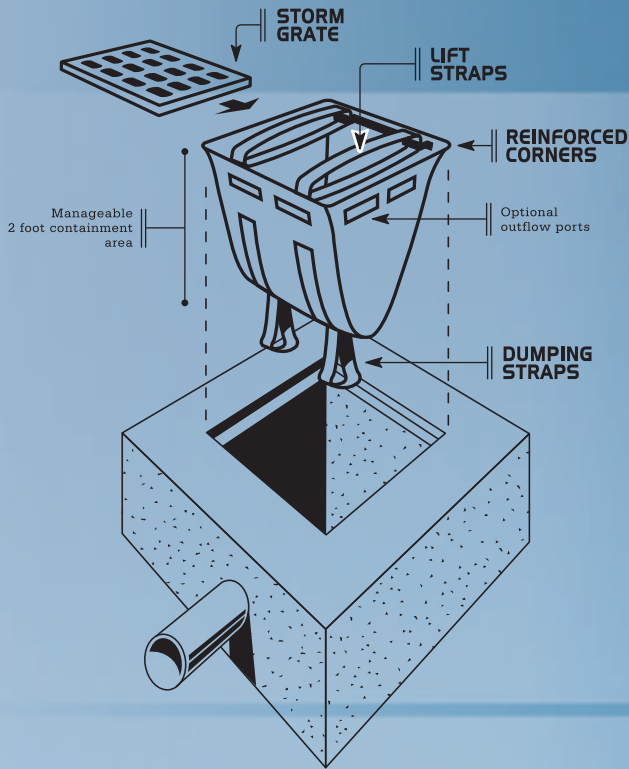

DANDY SACK®

Quality is what the Dandy Sack is all about. This incredibly strong open-top bag is specially designed to hang underneath a storm grate to expertly filter the thickest sediment-laden storm water. The suspended solids are allowed to settle out of the slowed flow and are conveniently captured by the Dandy Sack prior to entering the inlet, making the sturdy Dandy Sack a storm water must.

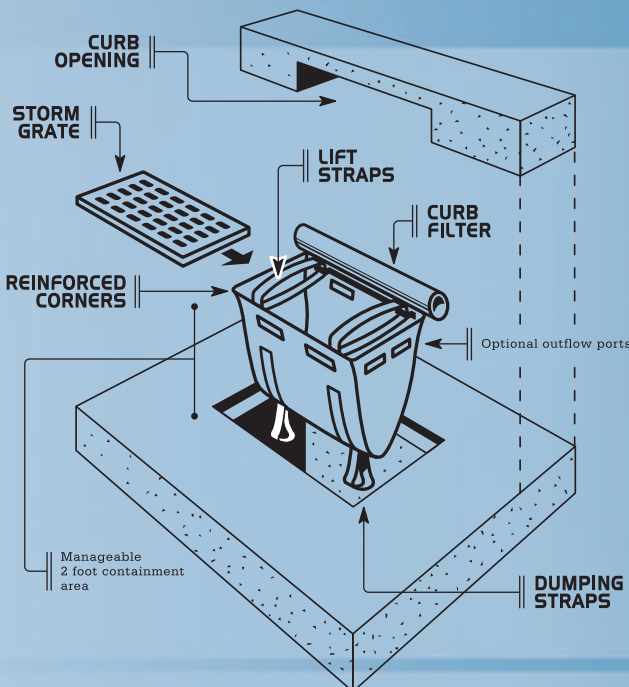

DANDY CURB SACK®

The rugged Dandy Curb Sack is extremely popular because it can handle jobs big and small and can be reused again and again. With an open-top design it fits to any size curb and gutter inlet. Its unique design allows it to filter sediment-laden water with ease. The suspended solids are allowed to settle out of the slowed flow and are captured quickly before entering the inlet. Once you've tried the durable Dandy Curb Sack you'll want to use them on every job.



DANDY CURB®

A study in durability is what you'll get with this Dandy Product. The Dandy Curb is made especially for curb inlets and median inlets without grates. It's designed to handle the worst that sludge-filled rainwater has to offer, filtering off sediment laden storm waters. The suspended solids are allowed to settle out of the slowed flow and are easily captured by the Dandy Curb prior to entering the inlet. Sediment doesn't stand a chance.

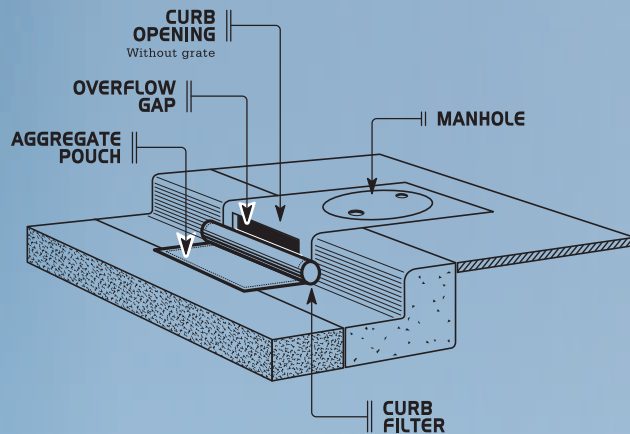

DANDY POP®

We are really excited about the patented Dandy Pop. It's designed for use with flat field grates to filter sediment-laden water and pops up in seconds. It's newly designed and hassle free so no more cumbersome silt fence or similar devices that either fall down or have infiltration points. The Dandy Pop fully encloses the grate, eliminating sediment infiltration. The suspended solids are allowed to settle out of the slowed flow and are easily captured prior to entering the inlet.

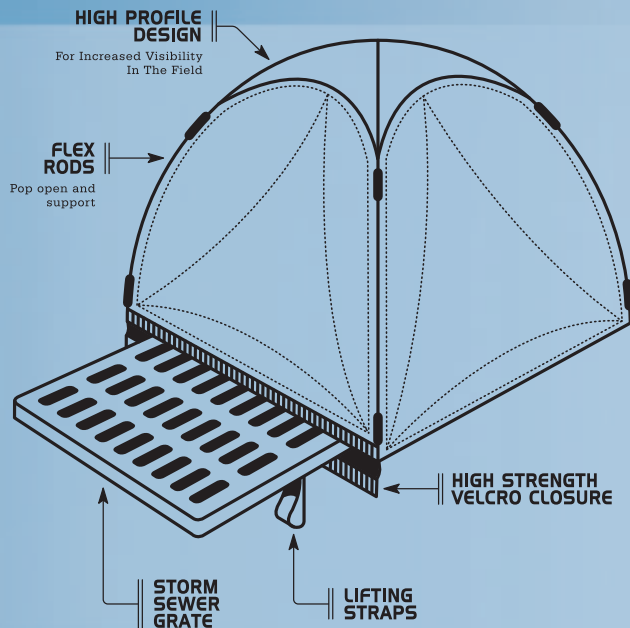

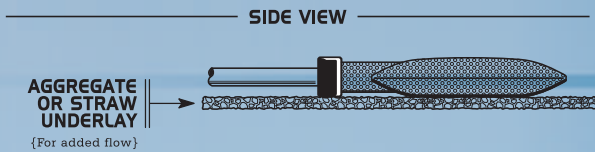
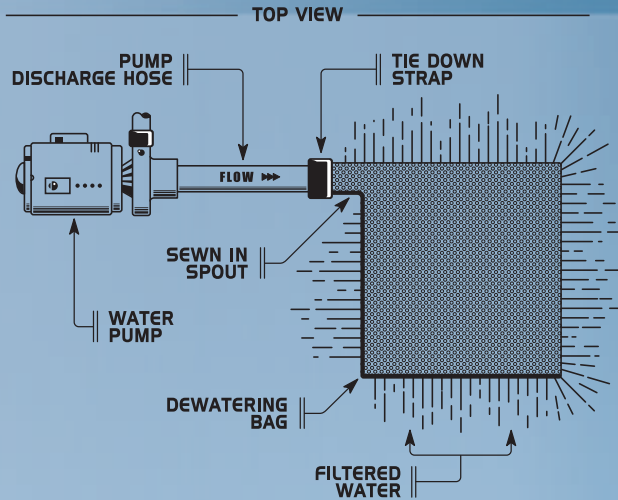

DANDY DEWATERING BAG®

Taking control to a new level, the Dandy Dewatering Bag is designed to control sediment discharge in dewatering applications where water is being pumped. When pumped water reaches the Dandy Dewatering Bag, the suspended solids are allowed to settle out of the slowed flow and are captured by the bag. Hassle-free and very convenient.

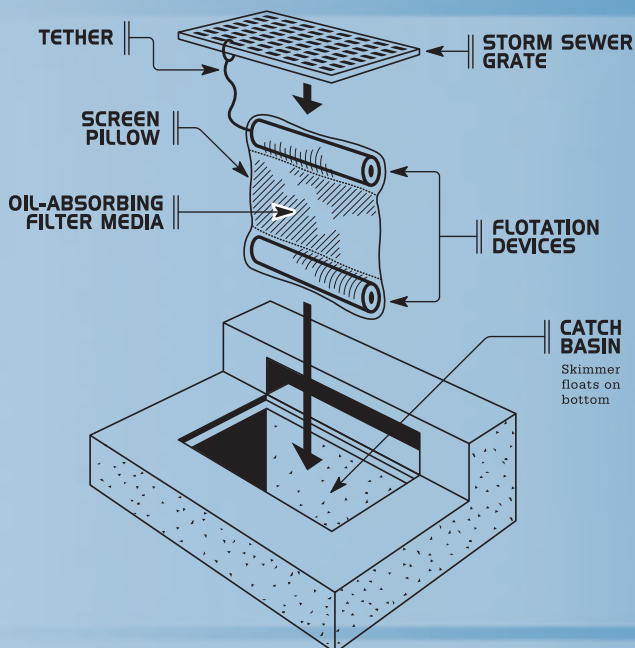

DANDY SKIMMER®

Oil contamination causing you a headache? May we suggest the Dandy Skimmer, it has got it all. Measuring 22" x 14" x 2" this uniquely designed screen pillow is filled with a polymer absorbent that has not one but two attached floatation devices. The oil absorbent material inside the skimmer easily captures the oil—permanently and continuously. We all know how difficult oil can be and the Dandy Skimmer can handle the worst of it.

Another Dandy Success Story

Application: Inlet Sediment Control
Location: Denver, CO
Products: Dandy Products

When Colorado Needed Long Term Statewide Development They Turned To Dandy

The Challenge:

With the new NPDES Storm Water Runoff regulations, the Colorado Department of Transportation needed to make sure they were up to code - an ongoing challenge in their 7-year reconstruction of Highway I-25.

The Solution:

They turned to Southeast Corridor Constructors (Kiewit) and Carter Burgess Engineering who then turned to Dandy Products. Dandy Products were picked for their superior filtering capabilities, the variety of products they carried, their bright colors (easy visibility), their low cost and ability to perform under construction loads.

The Results:

Dandy's inlet protection products were installed throughout the project and were used and re-used because they were properly maintained - this saved Denver both time and money. Performance studies have been done on Dandy Products by the Colorado DOT and the positive results have lead them to use more and more Dandy Products on construction projects throughout the state.



DANDY CURB BAG®

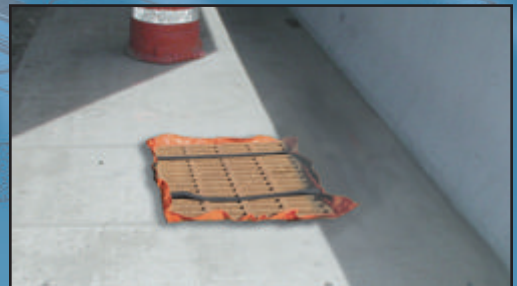

DANDY SACK®



DANDY POP®



Dandy Products, Inc
1095 Harcourt Road, Mount Vernon, OH 43050
Customer Service: 800.591.2284 • Fax: 740.397.1946

For complete product specs and information: www.dandyproducts.com • Twitter: @dandyproducts