

## Modular Wetlands<sup>®</sup> Linear Concrete Installation Manual

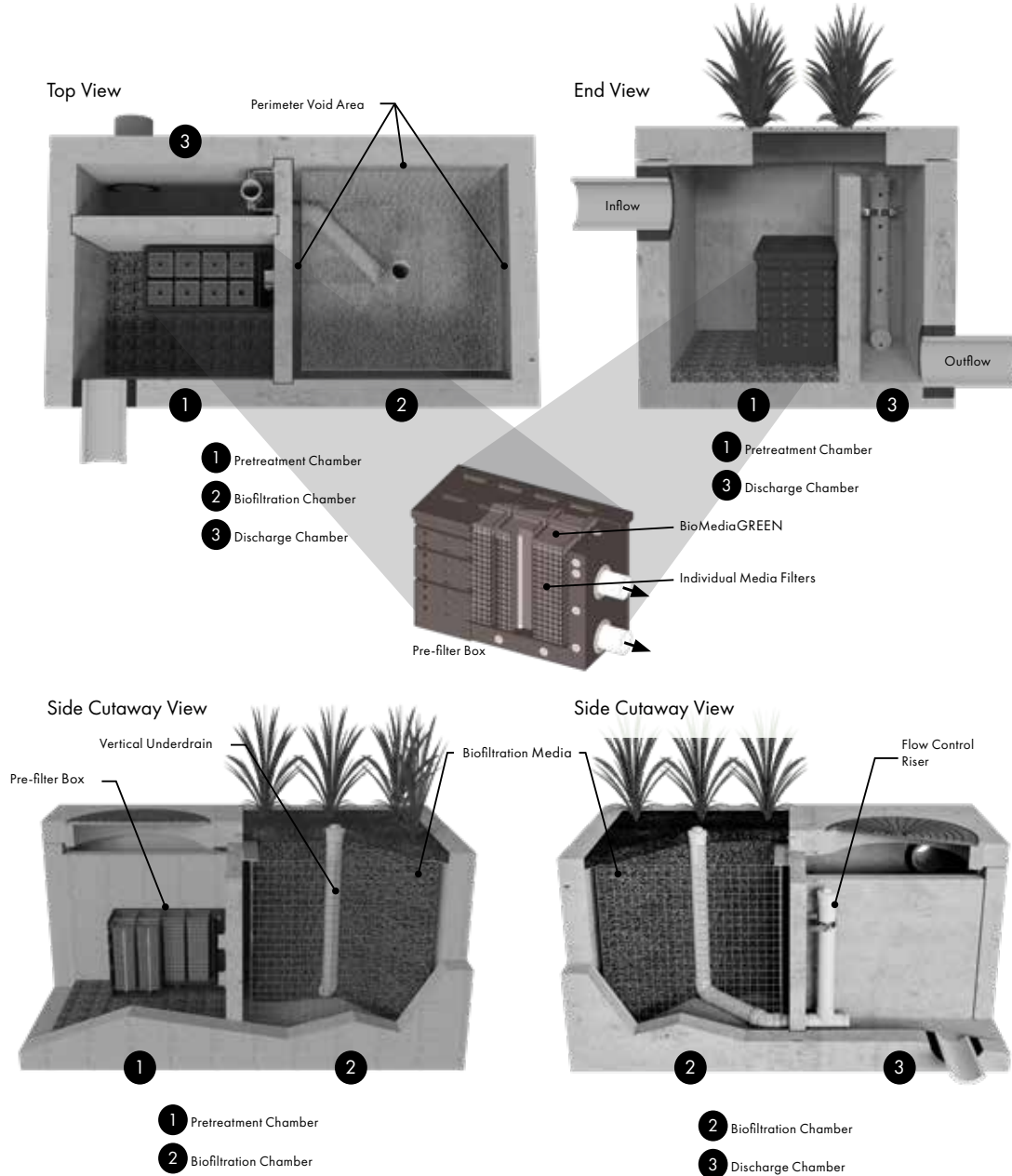

## Overview

The Modular Wetland® Linear Biofilter is designed to remove high levels of trash, debris, sediments, nutrients, metals, and hydrocarbons. Its simple design allows for quick and easy installation. The system is housed in a standard pre-cast structure and can be installed at various depths to meet site-specific conditions.



## Introduction

This is the Modular Wetlands® Linear installation manual. Before starting, make sure there is enough room for installing and assembling the product. Inspect all materials for defects and gather the recommended tools listed on the following page. The contractor shall furnish all labor, equipment, materials, and incidentals required to conduct the installation in accordance with the contract documents.

## Instructions

### *Delivery & Unloading / Lifting*

- Contech shall deliver the unit(s) to the site in coordination with the Contractor.
- The Contractor may be required to provide spreader bars and chains/cables to safely and securely lift the base section, risers, and top section along with suitable lifting hooks, knuckles, shackles and eyebolts.
- Please see project specific drawings for weights and lifting details. Contact Contech for additional lifting details.

### *Inspection*

Inspection of the Modular Wetlands® Linear and all parts contained in or shipped outside of the unit shall be inspected at time of delivery by the site Engineer/Inspector and the Contractor. Any nonconformance to approved drawings or damage to any part of the system shall be documented on the Contech shipping ticket.

- Damage to the unit during and after unloading shall be corrected at the expense of the Contractor. Any necessary repairs to the Modular Wetlands® Linear unit shall be made to the acceptance of the Engineer/Inspector.

### *Site Preparation*

- The Contractor is responsible for providing adequate and complete vault protection when the Modular Wetlands® Linear unit is installed prior to final site stabilization (full landscaping, grass cover, final paving, and street sweeping completed) to prevent construction debris or construction phase runoff from entering the unit.
- The Contractor shall adhere to all jurisdictional and/or OSHA safety rules in providing temporary shoring of the excavation.
- The Contractor or Owner is responsible for appropriately barricading the Modular Wetlands® Linear unit from traffic (in accordance with local codes).



- Each Modular Wetlands® Linear unit shall be constructed based on the locations and elevations according to the sizes shown on the approved drawings. Any modifications to the elevation or location shall be at the direction of and approved by the Engineer.
- The Modular Wetlands® Linear unit shall be placed on level compacted sub-grade with a minimum 6-inch gravel base. Compact undisturbed sub-grade materials to be per Geotechnical/Soils report. Unsuitable material below sub-grade shall be replaced to site engineer's approval. Place granular sub-base and compact to State and local standards as per the Engineers requirements.
- Once the base piece is set, the riser(s) and top section should be sealed onto the base section before backfilling, using a non-shrink grout, butyl rubber or similar waterproof seal.
- Pipe connections shall be aligned and sealed to meet the approved drawings with modifications necessary to meet site conditions and local regulations. The correct connection (inlet/outlet) will be marked on the Modular Wetlands® Linear unit.

- NOTE: The inlet and outlet pipe cannot protrude past the structures I.D. wall as it will interfere with the internal components.
- Once the Modular Wetlands® Linear unit is set, it should be protected from construction runoff entering it. Contractor will be responsible for cleaning if unit is contaminated by such construction runoff and associated pollutants and damaged (i.e. concrete wash water).
- Backfilling should be performed in a careful manner, bringing the appropriate fill material up in 6-inch lifts on all sides. Pre-cast sections shall be set in a manner that will result in a watertight joint. In all instances, installation of the Modular Wetlands® Linear unit shall conform to ASTM specification C891 "Standard Practice for Installation of Underground Precast Utility Structures" unless specified otherwise in contract documents.
- If applicable, it is the responsibility of the Contractor to provide curb and gutter and transition to the Modular Wetlands® Linear unit for proper stormwater flow into the system through the throat, pipe or grate opening. A standard drawing of the throat and gutter detail is available in the following section; however the plans and contract documents supersede all standard drawings. Several variations of the standard design are available. Effective bypass for an offline Modular Wetlands® Linear unit is essential for correct operation (i.e. bypass to an overflow at lower elevation).

## Installation

1. Each Modular Wetlands® Linear unit shall be constructed based on the locations and elevations according to the sizes shown on the approved drawings. Any modifications to the elevation or location shall be at the direction of and approved by the Engineer.



*Position crane in a safe and optimal position for unloading. Ensure that the crane operator has the proper weights and distance to install location to allow for proper setup. The crane operator will provide instructions to the delivery driver on where to position the truck for offload.*

2. The Modular Wetlands® Linear unit shall be placed on level compacted sub-grade with a minimum 6-inch gravel base and mark the base. Compact undisturbed subgrade materials to be per Geotechnical/Soils report. Unsuitable material below sub-grade shall be replaced to site engineer's approval. Place granular sub-base and compact to State and local standards as per the Engineer's requirements.

3. Pipe material selection should be indicated on the Site Plan. Connect the pipe using a Kor-N-Seal, Press Seal, Fernco, or other approved watertight boot connection. In the case of concrete pipes, grout the connection watertight with non-shrink grout.



*The contractor is responsible to provide the appropriate rigging and lifting connectors. Spreader bars are recommended to prevent damage to the concrete vault. All lifting points on the concrete vault must be used for safe offloading. Guide ropes can be used to stabilize the vault during offloading.*

4. Lift the vault off of the delivery truck and safely move vault over the excavated area for installation. Before setting the vault ensure the hole is the right size, level, and properly sized.



5. Position the concrete vault over the excavated area and slowly lower into position. Ensure the inlet and outlet sides of the vault are in the correct position and the correct elevations are verified.



6. Once the vault is set in place, check all four corners are in the correct position. Take tension off of the rigging to ensure the vault is set properly and the compacted rock backfill below is holding the weight of the vault.



7. Use a string and or level to make sure the vault is level in both directions. The vault cannot be more than 0.5% slope off from level in any direction. If the vault slopes more than 0.5%, pick back up, move to a safe area, re-level the rock below and reset until properly level.

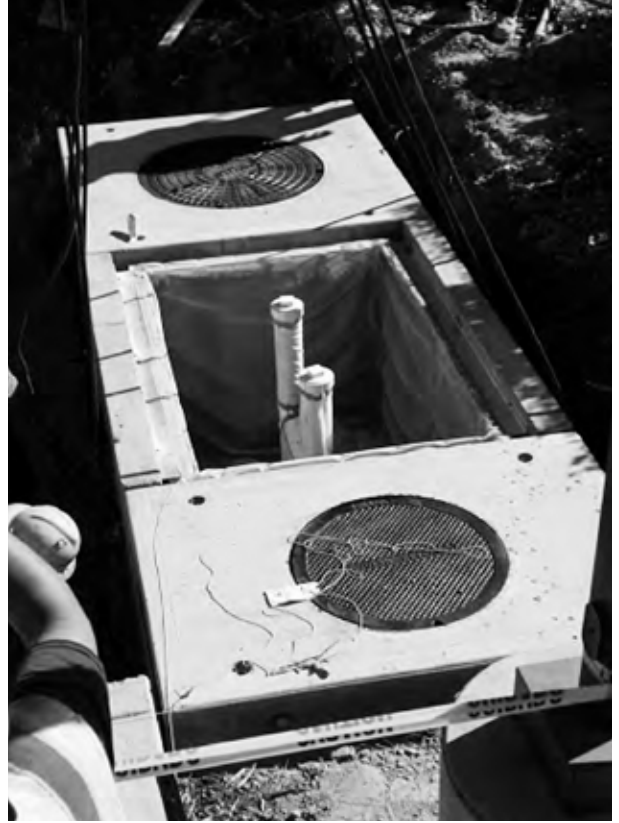

8. After pipe connections are completed, backfill in 12 inch increments and compact per local and state requirements. If curb type configurations, pour and connect curb and gutter system as shown in the picture to the right.

The last step is to install the wetland media that can be delivered in super sacks or in bulk based on preference. Install the plant propagation blocks as shown in the drawings below. Install the vegetation and cover with decorative rock and mulch.



## **Pipe Connections**

- Pipe material selection should be indicated on the Site Plan. Connect the pipe using a Kor-N-Seal, Press Seal, Fernco, or other approved watertight boot connection. In the case of concrete pipes, grout the connection watertight with non-shrink grout
- Inlet pipe(s) shall be stubbed in and connected to the precast manhole according to the Engineer's requirement or specifications. The Contractor is to grout all inlet pipes flush with the interior wall of the structure per plans and specifications.
- Outlet pipe shall be stubbed in and connected to the precast manhole according to the Engineer's requirement or specifications. The Contractor is to grout all inlet pipes flush with the interior wall of the structure per plans and specifications.
- For illustration a BAD example of a pipe installation is included below. The pipe is off-center, the pipe invert is not in the appropriate position, it is protruding beyond the inside wall, the grout is not clean and properly finished. This site was corrected by re-excavating and reconnecting the pipe properly.



*Example of a BAD pipe installation. Protruding past the internal wall of the structure, poor grouting, and wrong position.*



*Example of a GOOD pipe installation. Pipe flush with the internal wall of the structure, clean grouting, and proper position.*

- Once the pipes are connected, carefully backfill around them, compacting in "lifts" that will not deflect, disturb or damage them.

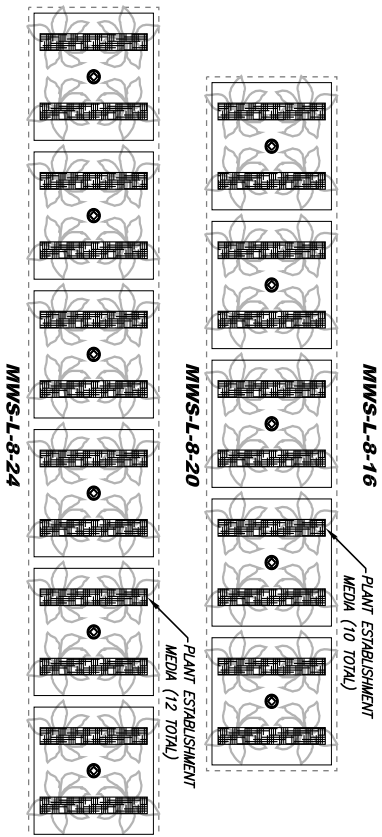
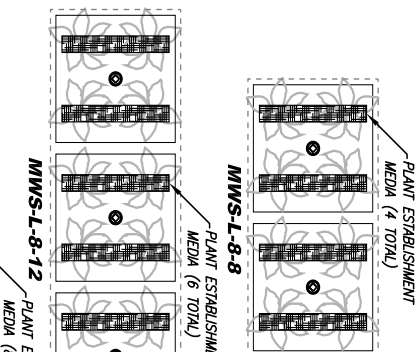
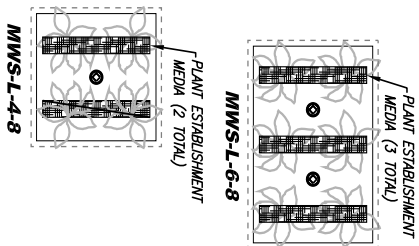
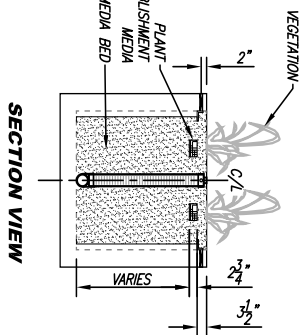
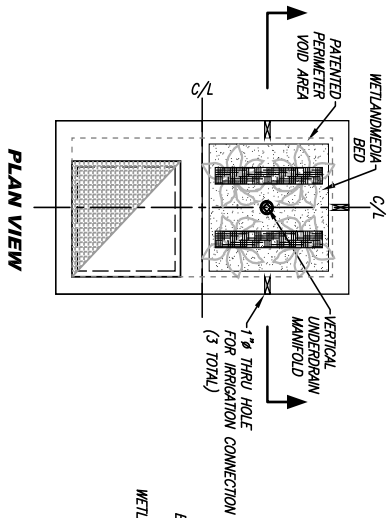

**VEGETATION AND IRRIGATION NOTES:**

1. VEGETATION SUPPLIED AND INSTALLED BY OTHERS. ALL UNITS WITH VEGETATION MUST HAVE DRIP OR SPRAY IRRIGATION SUPPLIED AND INSTALLED BY OTHERS.
2. BEFORE SELECTING VEGETATION SEE BIO CLEAN PLANT HARDY ZONE RECOMMENDATIONS.
3. IRRIGATION THRU HOLE IS 1 1/4" AND IS DESIGNED TO BE CONNECTED TO A 1 1/2" IRRIGATION LINE. IRRIGATION THRU HOLE IS LOCATED ON CENTER OF WETLAND CHAMBER 2" DOWN FROM THE TOP OF THE SYSTEM.
4. IRRIGATION SYSTEM FOR MODULAR WETLAND SYSTEM CAN BE PLACED ON SAME VALVE AS SURROUNDING PLANTING AREAS AND REQUIRES NO SPECIAL WATERING NEEDS.

**INSTALLATION NOTES**

1. CONTRACTOR TO PROVIDE ALL LABOR, EQUIPMENT, MATERIALS AND INCIDENTALS REQUIRED TO OFFLOAD AND INSTALL THE SYSTEM AND APPURTENANCES, IN ACCORDANCE WITH THIS DRAWING AND THE MANUFACTURER'S SPECIFICATIONS, UNLESS OTHERWISE STATED IN MANUFACTURER'S CONTRACT.
2. UNIT MUST BE INSTALLED ON LEVEL BASE. MANUFACTURER RECOMMENDS A MINIMUM 6" LEVEL ROCK BASE UNLESS SPECIFIED BY THE PROJECT ENGINEER. CONTRACTOR IS RESPONSIBLE FOR VERIFYING PROJECT ENGINEER'S RECOMMENDED BASE SPECIFICATIONS.
3. CONTRACTOR TO SUPPLY AND INSTALL ALL EXTERNAL CONNECTING PIPES. ALL PIPES MUST BE FLUSH WITH INSIDE SURFACE OF CONCRETE (PIPES CANNOT INTRUDE BEYOND FLUSH). INVERT OF OUTFLOW PIPE MUST BE FLUSH WITH DISCHARGE CHAMBER FLOOR. ALL PIPES SHALL BE SEALED WATER-TIGHT PER MANUFACTURER'S STANDARD CONNECTION DETAIL.
4. CONTRACTOR RESPONSIBLE FOR INSTALLATION OF ALL PIPES, RESERVOIR MANHOLES, AND TAPCHES. CONTRACTOR TO USE GROUT AND/OR BRICKS TO MATCH COVERS WITH FINISHED SURFACE UNLESS SPECIFIED OTHERWISE.
5. CONTRACTOR RESPONSIBLE FOR CONTRACTING BIO CLEAN FOR ACTIVATION OF UNIT. MANUFACTURER'S WARRANTY IS VOID WITHOUT PROPER ACTIVATION BY A BIO CLEAN REPRESENTATIVE.



PROPRIETARY AND CONFIDENTIAL: THE INFORMATION CONTAINED IN THIS DOCUMENT IS THE SOLE PROPERTY OF WETLANDS. IT IS TO BE USED ONLY FOR THE PROJECT AND NOT BE REPRODUCED OR COPIED IN ANY MANNER WITHOUT THE WRITTEN CONSENT OF WETLANDS.



STORMWATER BIOFILTRATION SYSTEM  
PLANTER INSTALLATION



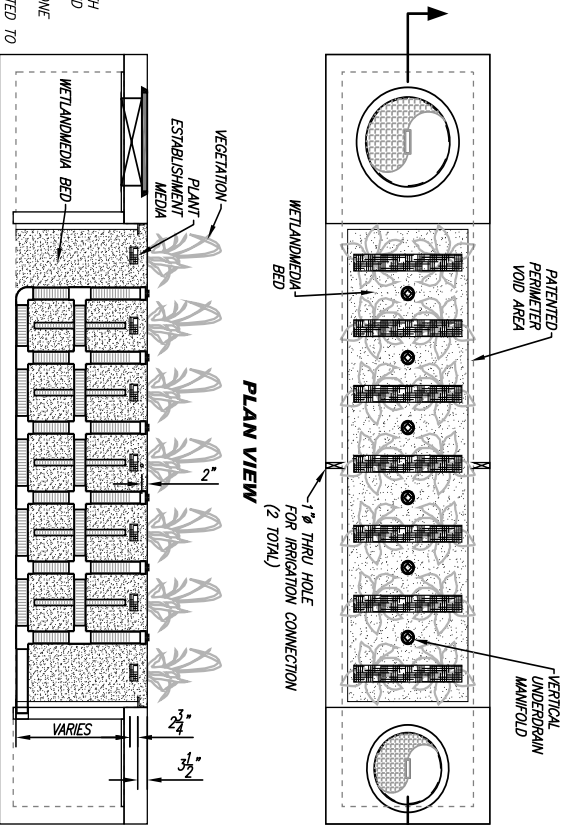

SECTION VIEW

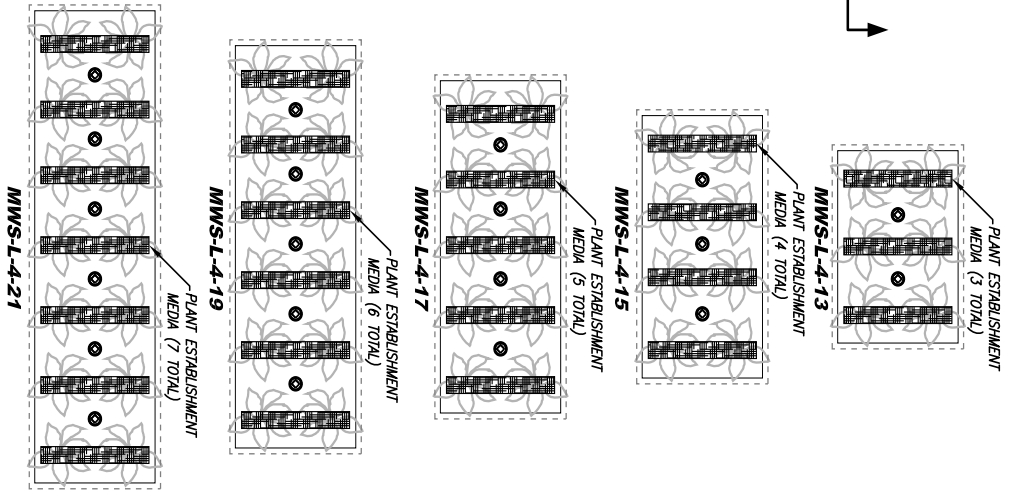

**VEGETATION AND IRRIGATION NOTES:**

1. VEGETATION SUPPLIED AND INSTALLED BY OTHERS. ALL UNITS WITH VEGETATION MUST HAVE DRIP OR SPRAY IRRIGATION SUPPLIED AND INSTALLED BY OTHERS.
2. BEFORE SELECTING VEGETATION SEE BIO CLEAN PLANT HARDY ZONE RECOMMENDATIONS.
3. IRRIGATION THRU HOLE IS 1"Ø AND IS DESIGNED TO BE CONNECTED TO A 1/2"Ø IRRIGATION LINE. IRRIGATION THRU HOLE IS LOCATED ON CENTER OF WETLAND CHAMBER 2" DOWN FROM THE TOP OF THE SYSTEM.
4. IRRIGATION SYSTEM FOR MODULAR WETLAND SYSTEM CAN BE PLACED ON SAME VALVE AS SURROUNDING PLANTING AREAS AND REQUIRES NO SPECIAL WATERING NEEDS.

**INSTALLATION NOTES**

1. CONTRACTOR TO PROVIDE ALL LABOR, EQUIPMENT, MATERIALS AND INCIDENTALS REQUIRED TO OFFLOAD AND INSTALL THE SYSTEM AND ADJUSTMENTS IN ACCORDANCE WITH THIS DRAWING AND THE MANUFACTURER'S SPECIFICATIONS, UNLESS OTHERWISE STATED IN MANUFACTURER'S CONTRACT.
2. UNIT MUST BE INSTALLED ON LEVEL BASE. MANUFACTURER RECOMMENDS A MINIMUM 6" LEVEL ROCK BASE UNLESS SPECIFIED BY THE PROJECT ENGINEER. CONTRACTOR IS RESPONSIBLE FOR VERIFYING CONTRACTOR TO SUPPLY AND INSTALL ALL EXTERNAL CONNECTING PIPES. ALL PIPES MUST BE FLUSH WITH INSIDE SURFACE OF CONCRETE (PIPES CANNOT INTRUDE BEYOND FLUSH). INNER OF OUTFLOW PIPE MUST BE FLUSH WITH DISCHARGE CHAMBER FLOOR. ALL PIPES SHALL BE SEALED WATERIGHT PER MANUFACTURER'S STANDARD CONNECTION DETAIL.
3. CONTRACTOR RESPONSIBLE FOR INSTALLATION OF ALL PIPES, RISERS, MANHOLES, AND HATCHES. CONTRACTOR TO USE GROUT AND/OR BRICKS TO MATCH COVERS WITH FINISHED SURFACE UNLESS SPECIFIED OTHERWISE.
4. CONTRACTOR RESPONSIBLE FOR CONTRACTING BIO CLEAN FOR ACTIVATION OF UNIT. MANUFACTURER'S WARRANTY IS VOID WITHOUT PROPER ACTIVATION BY A BIO CLEAN REPRESENTATIVE.



PROPRIETARY AND CONFIDENTIAL. THE INFORMATION CONTAINED IN THIS DOCUMENT IS THE SOLE PROPERTY OF METHLANDS. NO PART OF THIS DOCUMENT MAY BE REPRODUCED OR TRANSMITTED IN ANY MANNER WITHOUT THE WRITTEN CONSENT OF METHLANDS.



STORMWATER BIOFILTRATION SYSTEM  
PLANTER INSTALLATION

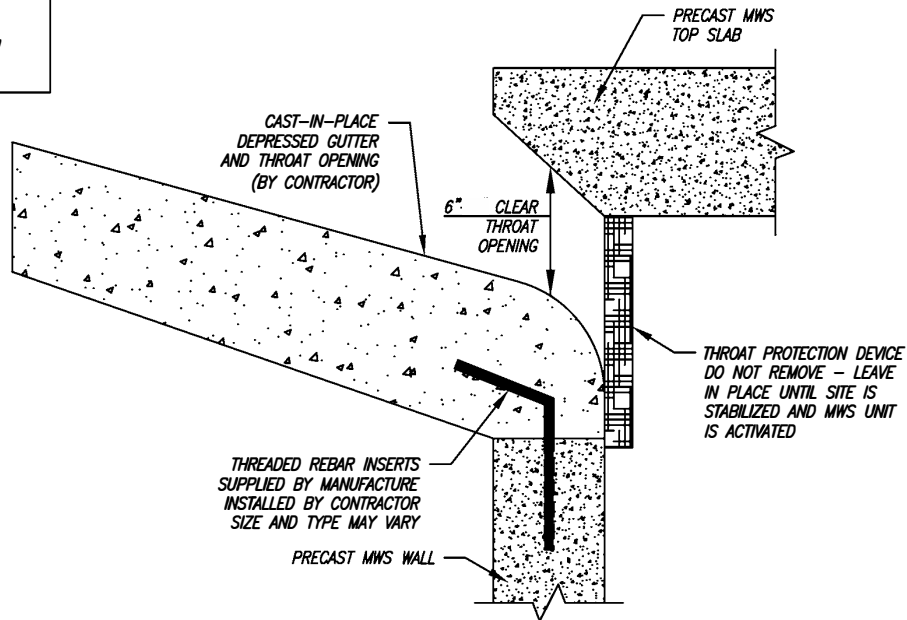

SECTION VIEW  
STANDARD MODULAR WETLAND CURB OPENING

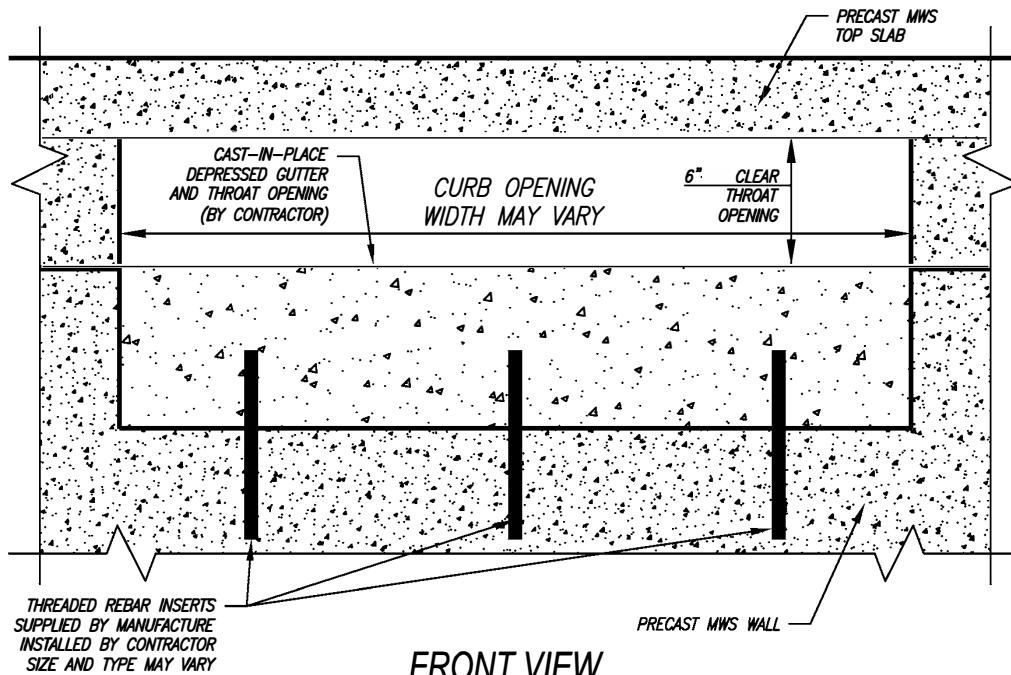

FRONT VIEW  
STANDARD MODULAR WETLAND CURB OPENING

MODULAR WETLAND SYSTEMS INC.  
P.O. BOX 869  
OCEANSIDE, CA 92019  
www.ModularWetlands.com

W/N  
EDITED

NAME DATE  
John 5/3/13

TITLE: MWS LINEAR 2.0  
CURB INLET DETAILS

PROPRIETARY AND CONFIDENTIAL

THE INFORMATION CONTAINED IN THIS DRAWING IS THE SOLE PROPERTY OF MODULAR WETLAND SYSTEMS INC. ANY REPRODUCTION IN PART OR AS A WHOLE WITHOUT THE WRITTEN PERMISSION OF MODULAR WETLAND SYSTEMS INC. IS PROHIBITED.

COMMENTS:

SIZE DWG. NO.

REV

SCALE NTS UNITS INCHES SHEET 1 OF 1





## **CONTECH**<sup>®</sup> ENGINEERED SOLUTIONS

© 2022 CONTECH ENGINEERED SOLUTIONS LLC, A QUIKRETE COMPANY

800-338-1122

[WWW.CONTECHES.COM](http://WWW.CONTECHES.COM)

ALL RIGHTS RESERVED. PRINTED IN THE USA.

CONTECH ENGINEERED SOLUTIONS LLC PROVIDES SITE SOLUTIONS FOR THE CIVIL ENGINEERING INDUSTRY. CONTECH'S PORTFOLIO INCLUDES BRIDGES, DRAINAGE, SANITARY SEWER, STORMWATER AND EARTH STABILIZATION PRODUCTS. FOR INFORMATION ON OTHER CONTECH DIVISION OFFERINGS, VISIT [CONTECHES.COM](http://CONTECHES.COM) OR CALL 800-338-1122.

NOTHING IN THIS CATALOG SHOULD BE CONSTRUED AS A WARRANTY. APPLICATIONS SUGGESTED HEREIN ARE DESCRIBED ONLY TO HELP READERS MAKE THEIR OWN EVALUATIONS AND DECISIONS, AND ARE NEITHER GUARANTEES NOR WARRANTIES OF SUITABILITY FOR ANY APPLICATION. CONTECH MAKES NO WARRANTY WHATSOEVER, EXPRESS OR IMPLIED, RELATED TO THE APPLICATIONS, MATERIALS, COATINGS, OR PRODUCTS DISCUSSED HEREIN. ALL IMPLIED WARRANTIES OF MERCHANTABILITY AND ALL IMPLIED WARRANTIES OF FITNESS FOR ANY PARTICULAR PURPOSE ARE DISCLAIMED BY CONTECH. SEE CONTECH'S CONDITIONS OF SALE (AVAILABLE AT [WWW.CONTECHES.COM/COS](http://WWW.CONTECHES.COM/COS)) FOR MORE INFORMATION.

### **SUPPORT**

DRAWINGS AND SPECIFICATIONS ARE AVAILABLE AT [WWW.CONTECHES.COM](http://WWW.CONTECHES.COM)

Modular Wetland Linear Install Guide 08/22