

**TIED CONCRETE BLOCK EROSION CONTROL MAT
SYSTEM SPECIFICATIONS - SHOREFLEX®**

1.0 SCOPE OF WORK

This section shall consist of the all the required work, material, and activities to ensure that the tied concrete block mats are both working properly and following the intent of its original design. The contractor shall furnish all labor, materials, equipment, and incidentals required for, and perform all operations in connection with, the installation of the ShoreFlex® system in accordance with the lines, grades, design, and dimensions shown on the Contract Drawings and as specified herein.

2.0 SUBMITTAL

Approved system is ShoreFlex®. Equals must meet all specifications outlined in Section 3.0 of this document and be approved by the EOR twenty (20) days prior to bid. Manufacturer will submit the performance testing and calculations in support of the ShoreFlex® erosion control system consistent with ASTM D6460-12. Reports of testing shall be complete and stamped from the testing lab. Prior ASTM methods to 2012 testing will not be accepted.

- a. Product must be TXDOT Approved.

3.0 MANUFACTURER

Tied Concrete Block Erosion Control Mat shall be ShoreFlex® as manufactured and sold by:

PREMIER CONCRETE PRODUCTS, INC.

38200 Hwy 16
Denham Springs, LA 70706
(800)-575-7293 / Fax: (225)-667-7424
www.shoreflex.com

Operating Hours: Monday thru Friday 7:00 AM – 5:00 PM CST

a. **APPROVED DISTRIBUTORS**

- Ferguson Waterworks
- ACF – Ferguson
- Industrial Fabrics, Inc.
- Premier Concrete Products, Inc.

4.0 ALTERNATE MATERIALS

Alternate Materials must be submitted 30 days prior to bid date for approval. Alternative materials from qualified suppliers may be considered; to qualify, proposed alternative suppliers must own and operate their own manufacturing facility, and shall directly employ a minimum of five (5) registered Professional Engineers. Full documentation consistent with the foregoing must be submitted in writing to the EOR a minimum of thirty (30) business days prior to bid date and must be pre-approved in writing as an addendum to the bid documents and drawings by the EOR at least twenty (20) business days prior to bid date. Submittal packages must also include, as a minimum, the following:

- 4.1 **Laboratory Testing:** Evidence of satisfactory full-scale laboratory testing in accordance with *ASTM D6460-12*, performed on behalf the submitting manufacturer on a qualifying test flume of sufficient length for the test flows under the design conditions of the specific project with full test reports provided, stamped, and signed by a registered Professional Engineer residing in and licensed to practice in the state where the project is located;
- 4.2 **Comparable Projects:** A list of 5 comparable projects, in terms of size and applications, in the United States, where the satisfactory performance of the specific alternate tied concrete block mat system can be verified after a minimum of five (5) years of service life. Qualification of Successful Installations: Alternate submittal must include the following information: Project name, Geographical Location, Owner, Specifying Engineer, Application (Slope, channel, outfall, etc.), Owner Reference;
- 4.3 **Certifications:** Information about, or certifications of, all materials associated with the tied concrete block mat system as detailed above, including (but not limited to) tied concrete block, geogrid, backing, and any other materials required for satisfactory installation;
- 4.4 **Contact Information:** The names and contact information (phone numbers and e-mail addresses, at a minimum) for the suppliers' representatives, for technical, production or logistics questions, at least one of whom must reside in the state where the project is located;
- 4.5 **Products:** Any products to be approved as alternate materials must meet **all** specified details contained within this document, including but not limited to:
- a. Concrete Blocks **must** be cast within a steel mold to maintain consistent size, shape, and weight
 - b. Block Dimensions
 - c. Block Nodes
 - d. Block Geometry
 - e. Backing Materials shall be attached with Mechanical Galvanized Hog Rings
 - f. Black Shrink Wrap Packaging
 - g. Certified Lifting Straps for Rolled Mats

5.0 PRODUCT

The manufacturer must be able to demonstrate a minimum of 25 years in manufacturing of hard armoring erosion control systems. Manufacturer will also demonstrate no less than 3 million square feet (detailed project list) of successfully installed flexible hard armor erosion control mats with substantial vegetation growth.

In order to analyze the performance of the unit, the hydraulic information listed below is required:

HYDRAULIC INFORMATION

Design Volumetric Flow Rate (ft ³ /sec)		<i>Specified by EOR</i>
Minimum Shear Stress (lb/ft ²)		
Channel Friction or Bed Slope (ft/ft)		
Channel Side Slopes (H:1V)		
Channel Bottom Width (ft)		

ShoreFlex[®] is manufactured from individual concrete blocks that are tied together to form an erosion control mat. Each concrete block within the mat will be tapered and uniform. Block interlocking will occur with the use of a high strength geogrid to ensure that no longitudinal or lateral movement of blocks occur during lifting or installation.

- 5.1 **Concrete compressive strength** must be a minimum 5,000 psi at 28 days as per ASTM standards C150 and C33 and tested in accordance with C39. The concrete blocks will be spaced no further than 1.5 inch, with +/- 0.25 inch tolerance apart creating an average minimum mat weight of 10.0 lb. per square foot. The concrete blocks must meet a minimum weight of 3 lbs each. Maximum absorption of the block is not to exceed an average of 10 lbs/cft.
- 5.2 **Cementitious Materials:** Materials shall conform to the following applicable ASTM specifications:
- Portland Cements:** Specification C150 for Portland Cement
 - Blended Cements:** Specification C595 for Blended Hydraulic Cements
 - Hydrated Lime Types:** Specification C207 for Hydrated Lime Types
 - Pozzolans:** Specification C618 for Fly Ash and Raw or Calcined Natural Pozzolans for use in Portland Cement Concrete
 - Aggregates:** Specification C33 for Concrete Aggregates, except that grading requirements shall not necessarily apply
- 5.3 **Concrete Casting:** The units shall be produced using wet cast method within a steel mold to maintain consistent size, shape, and weight.
- 5.4 **Mat Sizes:** The tied concrete block mats shall be fabricated at the manufacturer or another approved location into mats with a width of up sixteen (16) feet and a length up to fifty (50) feet, which is approved by the EOR. Custom mat dimensions may be available upon request.
- 5.5 **Mat Fabrication:** The mats shall have the ability for fabrication in various lengths, widths, and in combinations of length and/or widths. Special mats are a combination of two opposing dimensions either in the longitudinal or transverse direction of the mats. The special mats are available in various dimensions that allow for a custom fit to a site-specific project. Obstructions, such as manholes, pipe outfalls, or other fixed structures, will be accommodated to the extent that accurate information is provided about them prior to the preparation of mat layout drawings.
- 5.6 **Block Geometry and Dimensions** are listed below with a tolerance of +/- 0.25":

Height	Bottom Area	Top Area	Side Taper Angle	Bottom Surface Tolerance
2.5"	6.5" x 6.5"	1.5" x 1.5"	45 Degrees	+/- 0.1"

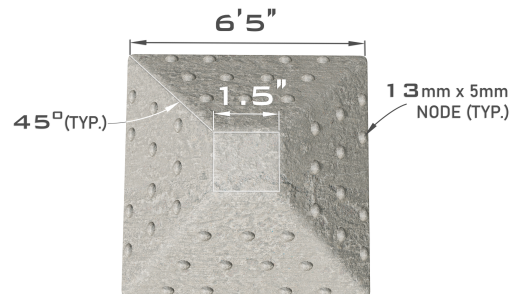
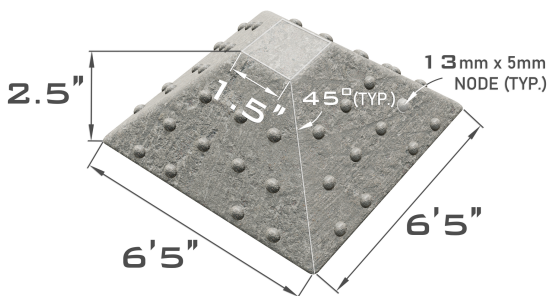

5.7 **Node Pattern:** Additionally, it is required the block has the following nodes pattern

# per Block	Node Size		
	# per Side	Width	Height
44	11	13MM	5MM

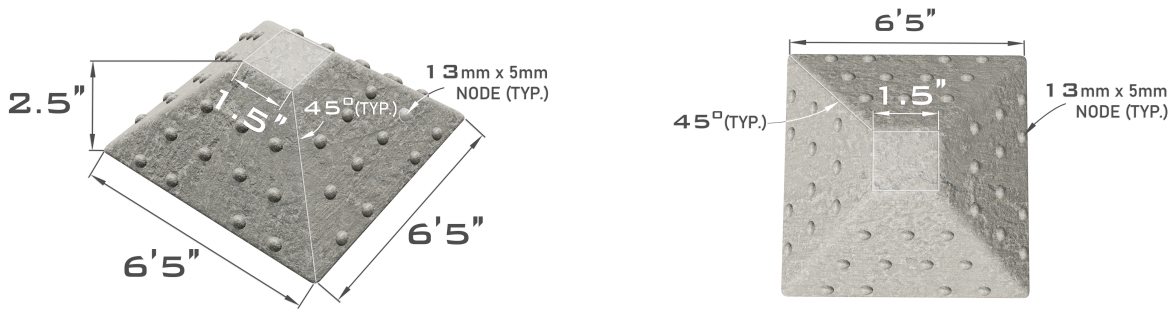

5.8 **Geogrid:**

The geogrid connection system is an open knitted fabric composed of high tenacity, multifilament polypropylene yarns knitted and coated in tension to form a stable grid structure. The geogrid is securely cast into and embedded within each concrete block to provide the connection strength. The geogrid will meet the requirements shown in the below table.

5.8.1: **Polypropylene geogrid system for interlocking concrete blocks**

Description	Minimum requirement	Testing Method
UV Stabilization	2%	Carbon Black
Ultimate Tensile Strength (MD and CMD)	30 kN/m (2,055 lb./ft.)	ASTM D6637
Elongation at Break	6%	ASTM D6637
Tensile Strength @ 2%	12 kN/m (822 lb./ft.)	ASTM D6637
Tensile Strength @ 5%	24 kN/m (1,646 lb./ft.)	ASTM D6637
Tensile Modulus @ 2%	600 kN/m (41,000 lb./ft.)	ASTM D6637
Tensile Modulus @ 5%	480 kN/m (32,900 lb./ft.)	ASTM D6637
Grid aperture size (MD and CMD)	1.6-1.9 inch	Length

5.9 **Backing Material:**

The use of a soil retention blanket as a backing material will be specified on a job-by-job basis. The selection of a particular retention blanket should be done by the design engineer or purchasing party. All soil retention blankets will be attached to the geogrid mat back via hog rings to ensure proper function of the underlying soil retention blanket.

5.9.1: Standard Polypropylene turf reinforcement backing to meet the following standards

Property	Test Method	English	Metric
Roll Size		8 ft X 112.5 ft	2.4 m x 34.29 m
Physical			
Mass / Unit Area	ASTM D6566	10.0 oz / yd ²	340 g / m ²
Thickness	ASTM D6525	0.40 in	10.1 mm
Light Penetration (% Passing)	ASTM D6567	20%	20%
Color	Visual	Green	
Mechanical			
Grab Tensile Strength	ASTM D6818	400 x 300 lb / ft	5.8 x 4.3 kN / m
Grab Elongation	ASTM D6818	50% (max)	50% (max)
Resiliency	ASTM D6524	90%	90%
Flexibility	ASTM D6575	0.026 in / lb (avg)	30,000 mg / cm (avg)
Endurance			
UV Resistance @ 1000 hours	ASTM D4355	80%	80%

5.10 **Mechanical Connectors:**

Connections between tied concrete block mats and backing materials shall be galvanized mechanical hog rings.

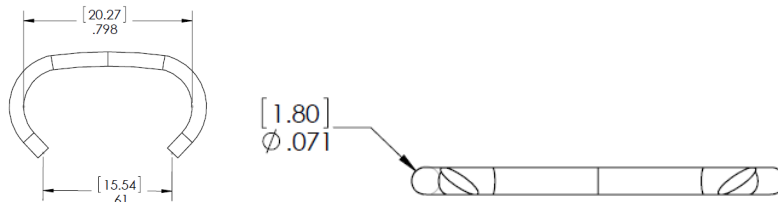

(mm) inch

5.11 **Physical Requirements:** At the time of delivery to the work site, the units shall conform to the physical requirements prescribed in the table listed below. Units will be sampled and tested in accordance with *ASTM C39*.

Compressive Strength Net Area (Min. P.S.I.)		Water Absorption (Max. lb/ft ³)	
Avg. of 3 units	Individual Unit	Avg. of 3 units	Individual Unit
5,000	4,500 (24.1)	10.0	11.7

5.12 **Visual Inspection:** All units shall be sound and free of defects which would interfere with the proper placement of the unit, or which would impair the performance of the system. Surface cracks incidental to the usual methods of manufacture, or surface chipping resulting from customary methods of handling in shipment and delivery, shall not be deemed grounds for rejection.

Chipping resulting in a weight loss exceeding 15% of the average weight of a concrete unit OR spacing between blocks exceeding 2.0 inches shall be deemed grounds for rejection.

Blocks rejected prior to delivery from the point of manufacture shall be replaced at the manufacturer's expense. Blocks rejected at the job site shall be repaired with structural grout or replaced upon request at the expense of the contractor.

5.13 **Lifting/Anchoring Loops:** Anchoring of the mats shall be done via the embedded lifting / anchoring loops. The concrete embedded lifting/anchoring loops will be made from a 3/16 in. Polypropylene rope with a 450 lb. (2.13 kN) tensile strength, allowing for ease of mat maneuvering during edge along the sides every 5 blocks. Anchoring systems can be recommended by the manufacturer or engineer for specific site conditions.

6.0 DELIVERY, HANDLING, AND STORAGE

ShoreFlex® will be rolled and or in mat form packaged with lifting straps and black shrink wrapping around the tied concrete block mat roll. Spreader bar may be obtained from supplier if needed.

Upon delivery, rolls or mats should be inspected to ensure that all of the units are free of defects that may hinder either performance or installation of ShoreFlex®. Delivered rolls or mats should not be left exposed for more than 30 days to ensure protection from UV light.

Missing concrete due to chipping or cracking shall not exceed 15% of the average concrete unit weight. If the threshold of 15% is surpassed the material may be rejected by the engineer. Repair, patch, or replacement of the affected area should be done per the manufacturer's recommendation.

7.0 PERFORMANCE TESTING

ShoreFlex® will resist erosion and scour due to hydraulic forces. ShoreFlex® will meet the requirements listed in Table 2 when tested with a backing material on a non-vegetated surface. 30% testing is not recommended for ASTM D6460-12 due to slope stability during testing.

7.1 Table Limiting shear stress testing, ASTM D6460-12

Test	Tested value	Bed Slope	Limiting Value
ASTM D6460-12	Shear Stress	10% & 20%	18 lb./ft. ²
ASTM D6460-12	Velocity	10% & 20%	30 ft./sec

7.2 **Sampling and Testing:** The purchaser (or their authorized representative) shall be accorded access to the relevant manufacturing facility or facilities, if desired, in order to inspect and/or sample the units from lots ready for delivery prior to release for delivery to the job site. Such inspections are at the sole expense of the requesting entity.

Purchaser may request additional testing other than that provided by the manufacturer as needed. Such requested testing will extend any stated lead times for manufacturing and delivery, if the results of such testing are a prerequisite to approval (i.e., approval for release to manufacturing). Costs associated with such testing shall be borne by the purchaser.

8.0 ANCHORING SYSTEM

The specifying EOR *may* require, at their discretion, permanent anchoring of the mats, e.g., by the use of ancillary earth anchors or attachment to other structures using the lifting cable loops, or through the openings within the grid spacing. The design of the ShoreFlex[®] system is intended to provide hydraulic stability without the use of such anchors; consequently, any such anchor design shall be by others as approved by the EOR.

9.0 FOUNDATION PREPARATION AND MAT PLACEMENT

9.1 Installation

ShoreFlex[®] installation shall be performed by a manufacturer approved installer. All equipment, materials, labor, and incidentals associated with placing ShoreFlex[®] are to be covered by the approved installer.

Subgrade prep should follow the construction plans submitted either by the engineer or manufacturer. The subgrade should be smooth, firm, unyielding, and free from all debris including sticks, rocks, roots, and other protrusions that would inhibit intimate contact with the subgrade. No individual block should be raised more than $\frac{3}{4}$ in. above the immediately adjacent block to ensure proper hydraulic performance. Compaction of base to meet 95% proctor unless specified otherwise.

Topsoil and seed can be applied directly to prepared subgrade prior to the placement of the ShoreFlex[®] to obtain desired expedited vegetation growth.

Mats should be installed according to the line and grade shown in the plans that have been provided by the engineer or the manufacturer. Onsite technical assistance will be available from the manufacturer during installation if needed.

Installation of adjacent mat seams perpendicular to the flow should be done with a shingle installation method. The downstream mat should be placed a minimum of 18 in. underneath the upstream adjoining mat and can be fastened together as per the engineer or manufacturer's recommendation.

Installation of adjacent mat seams parallel to the direction of flow should not meet in the middle of the channel and should have a 2ft. erosion control blanket placed equally under both mats and both mats shall be fastened together using the engineer or manufacturers recommendation.

A minimum toe trench of 18 in. should be dug for the leading edge of the concrete mat that is perpendicular to channelized flow. All exterior edges of the concrete mat not exposed to channelized flow should be trenched in a minimum of 3". The leading edge and sides of the mat will be placed in the trenches and backfilled with a non-erodible soil or site-specific soil.

Additional anchoring can be achieved by using the lifting/anchoring loops that are embedded into the concrete blocks at the edges of each mat. Each loop can be used to adjust mats during installation as well as be used for attaching earth anchors to permanently hold the concrete mats in place.

9.2 **Finishing:** The cells or openings in the mats may be backfilled and compacted with suitable material, as specified by the EOR. Backfilling and compaction shall be completed in a timely manner so that no more than 500 feet of exposed mats exist at any time. Finishing requirements are explicitly at the discretion of the EOR.

10.0 PRICE AND PAYMENT

10.1 Measurement and payment

This item shall be measured by the square foot as shown on the plans also taking into account the toe-in square footage. Total project square footage can be confirmed by the manufacturer with accompanied layout drawings.

The materials furnished for the installation of this item shall be paid for at the quoted unit price from manufacturer. The price is full compensation for the assembly and loading of the product for shipment to jobsite or otherwise specified assembly area. Price does not include transporting, equipment, materials, labor, and incidentals associated with placing ShoreFlex[®].