

# The GeoCURVE Inlet Filter

## Attention Erosion and Environmental Engineers & Contractors

The City of Austin has adopted new criteria for curb inlet protection. The City of Austin criteria has the following requirements.

Curb Inlet Protection Devices:

- ✓ Should not cause flooding when it clogs with debris
- ✓ Should not be secured or attached by the use of sand bags
- ✓ Should completely cover the opening of the inlet, and be installed without protruding parts that could be a traffic, worker, or pedestrian hazard
- ✓ Should be attached in a way that they can be removed easily
- ✓ Should maximize pollutant reduction
- ✓ Should require inexpensive maintenance

### CURRENT PRACTICE IN CENTRAL TEXAS: Z DYKE Inlet Protection:



The most common form of inlet protection devices are Z Dykes that utilize sand bags to hold them in place. Z Dyke inlet protectors and the corresponding sandbags are exposed to the elements and generally degrade fairly rapidly. When the sand bags rupture they release an average of 1 cubic foot of sediment per bag directly into the storm inlet, and into its related waterway. As sediment and debris accumulate around the opening the refuse piles up and overflows into the street. Z Dykes and similar products pose a pedestrian and traffic hazard. Further, the sediment pollutants that collect in front of the storm drain typically end up going directly into the inlet upon removal of the protection device.

## NEW and IMPROVED SOLUTION: GeoCURVE Inlet Filter:

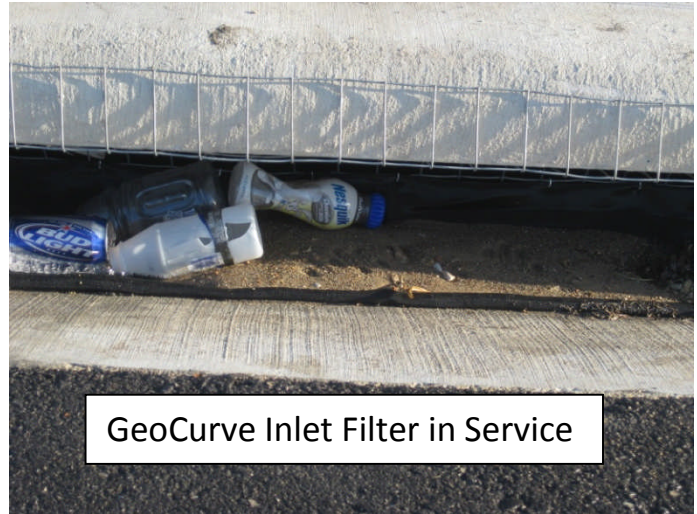
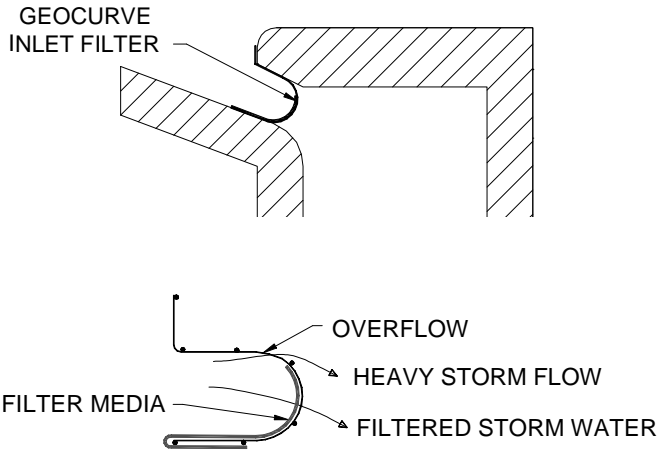

GEOCURVE INLET FILTER  
CROSS-SECTION

The GeoCurve Inlet Filter is an innovative device created by GeoSolutions, Inc. to comply with the new City of Austin requirements while increasing the performance of inlet protection. GeoCurve's patented design incorporates a compression fit into the throat of the inlet so that sand bags are no longer needed. The device easily installs into the throat of the inlet so that there are no exposed elements to pose a hazard to traffic or pedestrians. The GeoCurve shape creates a sediment collection trough inside the throat of the inlet that captures unsightly trash and sediment making for a more aesthetic solution. The device incorporates a high flow filter fabric and an overflow opening that will provide efficient filtering and still pass high flow during heavy storm events. The GeoCurve is easily maintained by removing the device by pulling on the bottom edge of the inlet filter and dumping the captured debris and sediment in a designated location where they can not pollute our waterways. Once the accumulated debris and sediment is removed from the GeoCurve Inlet Filter it can be reinstalled for continued service.

The GeoCurve Inlet Filter has been hydraulically tested with excellent results. The device was able to pass 350 gallons/minute without backing up water into the street.

For more information on the GeoCurve Inlet Filter please contact your local GeoSolutions, Inc. sales representative.

Another Innovative Solution from:

